

wodtke Pellet Stove Technology

Quick Operating Instructions for

ivo.tec[®] and **ivo.safe**[®]

Control System S5

for Software BM 010 and Higher



CAUTION:

Please also read the general operating and assembly instructions.
This is a short version of the operating instructions which explains only the most important commands and display messages. It is neither complete nor sufficient in itself!

We hope your pellet stove gives you many hours of warm, snug comfort in your home.

wodtke GmbH

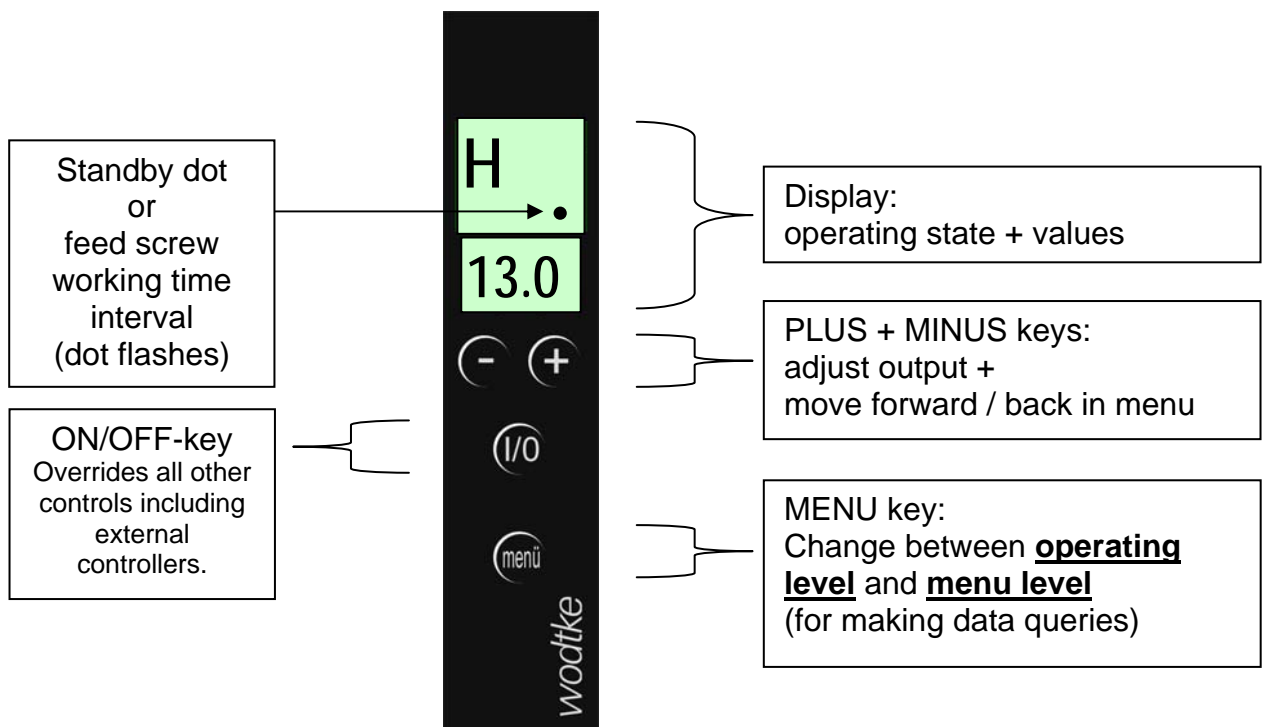

Display Messages

Display message	Explanation
●	“Standby dot” ; appliance has been switched off manually via I/O key. Press the I/O key to switch on the stove. The stove does not respond to external controllers when in standby mode.
ON	ON start signal (appears briefly when you switch on the stove) The stove has been started. After briefly showing the programme being used it enters the TEST phase.
OFF	OFF stop signal (appears briefly or alternates with “A” for 4 minutes when you switch off the stove) The stove has been switched off and after going through phases A1 – A4 enters fan after-run phase G OFF.
B1 001	This is the programme and programme version (appears for some seconds during start-up). B1 = programme 3 – 9 kW; B2 = programme 3 – 11 kW; B3 = programme 3 – 13 kW; B4 = programme 3 – 13 kW 001 = programme version 1; 002 = programme version 2; flashes alternately with TEst (see below).
TE st	TEST phase (appears after starting the stove) Checks all stove functions; flue gas exhaust flap cycle starts. If no error is found during the test phase, the stove enters the preheating programme (A). This display message flashes alternately with B1 – B4.
A 1	Indicates that the Preheating Programme is running and its duration in minutes (which is variable). The stove begins to feed pellets into the firebox, the ignition element starts, and the ignition process is monitored (after successful completion of the preheating phase the stove enters the heating programme (H); example: A1 minute 1 of preheating programme; A8 minute 8 of preheating programme...
AI ...	Preheating programme in + number of minutes (flashes alternately with G OFF) The stove is still in G OFF. However, the stove has registered that the I/O key has been pressed again. It is indicating that it will <u>automatically resume operation</u> in x minutes (after completion of G OFF). example: AI 11 = preheating will start in 11 minutes.
H ...	Heating programme + set thermal output in kW The stove is in heating mode, example: H 8.0 = heating programme running at 8 kW.
H.M 3.0	Heating programme internal minimum + thermal output in kW → The heat generated by the stove is not being fed into the heating system / is not required. Thermal output has been reduced to a minimum (3 kW) by an internal controller because boiler water temperature TW > 80°C. The stove will re-enter the heating programme (H) when the temperature has dropped sufficiently. Note: Don't confuse H.M (internal) with HM (no dot – external).
R -15	Cleaning programme (R) + remaining number of minutes (flashes alternately with G OFF) After 4 hours continuous operation the stove starts an <u>automatic cleaning cycle</u> of 15 minutes duration. First the stove switches to fan after-run (R-15 and G OFF flash alternately), then the ash is removed. Note: The stove restarts automatically after completion of the cleaning programme R.
G OFF	Fan after-run (=stove switches off and ash is removed; 15 minutes duration) The fan runs for another 15 minutes (the remaining pellets burn down, the flue gas is carried off, ash is removed). Note: Only when G OFF does not flash alternately with R, AI, HE OFF or TW OFF does the stove go into standby when fan after-run is over. In all other cases the stove restarts automatically after fan after-run is over.
TW OFF	Heat exchanger is cut off by a thermal switch (→ heat is not fed into the heating system) The stove switches off via an internal control mechanism because boiler water temperature TW > 85 °C. The stove restarts automatically after the temperature has dropped sufficiently.
RA ...	Cleaning prompt (appears briefly) The stove needs <u>cleaning</u> ; example: RA 0.1 = cleaning overdue since 0.1 t pellets.
WA ...	Service prompt (appears briefly) The stove needs <u>servicing</u> . example: RA 0.1 = servicing overdue since 0.1 t pellets.
PL AUF	Fuel hopper open The hinged cover of the fuel hopper is open. If it is open for longer than 3 minutes without interruption while the stove is in operation (display shows Test, A, H, HM, H.M, HE, G OFF), this will produce an error shutdown (PL Err).
AL AUF	Ashpit door open The ashpit door is open in standby mode. If it is open for longer than 3 minutes without interruption while the stove is running (display shows Test, A, H, HM, H.M, HE, G OFF), this will immediately cause an error shutdown (AL Err). Only open the ashpit door when the stove is not running!
FT AUF	Firedoor open The firedoor is open in standby mode. If the firedoor is opened while the stove is in operation (display shows Test, A, H, HM, H.M, HE, G OFF), the stove will immediately produce an error shutdown (FT Err). Only open the firedoor when the stove is not running!
PE res	Fuel level below reserve line The fuel hopper is almost empty and should be refilled immediately. If the display message PE res appears for longer than 5 minutes the stove will produce an error shutdown (PE Err).
●● ●●●	“Function currently not available” This display message appears when the function you have called up is currently not available (e.g. switching off the appliance while an automatic routine such as grate cycle/ash removal is still running).
HE ...	Externally controlled heating programme (only possible with external <u>modulating</u> controller) The stove is being operated at the indicated output level via an external modulating controller; example: HE 7.2 = heating programme running at 7.2 kW via an external controller
HM 3.0	Heating programme running at minimum level (only possible with external controller) The stove has been set to its minimum output level (3 kW) via an external controller (MIN/MAX input). Note: Don't confuse H.M (dot between H and M – internal) with HM (no dot – external).
HE OFF	Heating programme switched off via external controller (only possible with external controller) The stove has been switched off via an external controller (via input ON/OFF or BUS or TC1).

Error Codes

In the event of errors of error class 1 (F1) use the error code to find the cause of the error, rectify the error and then do a reset by pressing the I/O key. In the event of class 2 errors (F2) the stove automatically carries out a reset as soon as the cause has been eliminated.

Display message	Error class (F1) or (F2) / Cause of error
RE Er1	(F1) – Bridge wire at “auxiliary input” (RE) open or error in external component/device connected to it.
PE Err	(F1) – Fuel level (error message “PE Res”) permanently below reserve line / minimum filling level for longer than 5 minutes → replenish pellets!
RO Err	(F1) – Grate hasn’t reached “open” position (RO) → ashpit full (→clear ashpit). Swivelling grate possibly soiled / jammed or grate motor / limit switch / grate axis driver / cabling defective.
RG Err	(F1) – Grate hasn’t reached “closed” position (RG) → ashpit full (→clear ashpit). Swivelling grate possibly soiled / jammed or grate motor / limit switch / grate axis driver / cabling defective.
Z Err	(F1) – Ignition error. Flue gas temperature (TR) hasn’t risen to the required degree after starting.
ST	(F1) – STB (a safety device) has triggered. Temperature at heat exchanger too high
TR	(F1) – Flue gas temperature (TR) too low during operation
TR Er1	(F1) – Flue gas temperature sensor (TR) broken
TP	(F1) – Temperature at pellet chute (sensor TP) too high
TP Er1	(F1) – Pellet chute temperature sensor (TR) broken
TP Er2	(F1) – Pellet chute temperature sensor (TP) shorted
HB Er1	(F1) – Defect in operating panel/operating panel cable or communication with TC1 Touch Control (optional)
HP Er1	(F1) – 24 V inputs to main circuit board defective or wrongly connected
HP Er2	(F1) – Reference temperature sensor on main circuit board defective
HP Er3	(F1) – Write/Read error by EEPROM on main circuit board
LM Er1	(F1) – Air flow sensor (LM) broken
LM Er2	(F1) – Air flow sensor (LM) shorted
TL HI	(F1) – Temperature at air flow sensor (TL) too high
TL Grd	(F1) – Temperature gradient at air flow sensor too high
TW Er1	(F2) – Temperature sensor in heat exchanger (TW) broken
TW Er2	(F2) – Temperature sensor in heat exchanger (TW) shorted
L- LO	(F2) – Lower air flow limit exceeded
RA Err	(F1) – Cleaning (1.0 t) severely overdue
WA Err	(F1) – Servicing (3.0 t) severely overdue
AL Err	(F1) – Ashpit door open during operation
PL Err	(F1) – Fuel hopper open for too long
FT Err	(F1) – Firedoor open during operation
R4 Er1	(F1) – “auxiliary output 4” (safety relay) defective
GD Err	→ Currently not active
BU Er1	(F2) – BUS error (defect in bus communication or input RS 485)

Data Queries

Press "Menu" key once. Use the "+" and "-" keys to move through the menu.

Display message Menu level	Explanation	Remarks
BM 001, 002...	Currently installed software version	Identifies the basic software installed on the main circuit board (cf. computer operating system).
Z ON / OFF	Z ON = ignition on Z OFF = ignition off	Shows whether the "Zündung Z" (ignition) output is live (ON) or not (OFF).
S ...	Feed screw interval in seconds	Shows the current working time interval of the feed screw in seconds; this determines pellet feed rate.
PE CAL	Calibration routine for pellet throughput	Start routine here. Observe Operating Manual! Permits adjusting pellet throughput according to pellet type or batch.
U ...	Fan speed in %	Shows the current voltage at the "fan" output in terms of % of nominal voltage.
L ...	Air flow rate at the air flow sensor in m ³ /h	Shows the combustion air flow currently measured by the air flow sensor (LM) in terms of m ³ /h.
TP ...	Temperature at pellet chute in °C	Shows the temperature currently measured by the TP sensor at the pellet chute.
TL ...	Temperature at air flow sensor in °C	Shows the temperature of the combustion air currently measured by the LM in the suction pipe.
TR ...	Flue gas temperature in °C	Shows the combustion temperature currently measured by the TR sensor in the firebox.
TW ...	Temperature at water heat exchanger in °C	Shows the water temperature currently measured by the internal boiler sensor in the heat exchanger.
P ON / OFF	Pump relay (make-contact relay) P ON = pump on = 230 V or mains voltage P OFF = pump off = 0 V	Shows whether the "Pumpe" (pump) output is live (ON) or not (OFF).
R1 ON / OFF	Auxiliary relay 1 (make-contact relay) R1 ON = 230 V or mains voltage R1 OFF = 0 V	Functional message ON = stove is running (though error may be present) OFF = stove not in operation
R2 ON / OFF	Auxiliary relay 2 (make-contact relay) R2 ON = 230 V or mains voltage R2 OFF = 0 V	Collective error message ON = no error OFF = has produced an error shutdown / has been switched off manually
R3 ON / OFF	Auxiliary relay 3 (make-contact relay) R3 ON = 230 V or mains voltage R3 OFF = 0 V	Error message from temp. sensor at pellet chute (TP) ON = temperature at pellet chute (TP) too high OFF = temperature at pellet chute (TP) ok
R4 ON / OFF	Auxiliary relay 4 (break-contact relay, potential-free, max. load 2 A) R4 ON = relay open R4 OFF = relay closed	Functional message (via monitored potential-free safety relay) ON = stove is running (though error may be present) OFF = stove not in operation
BW ...	Operating hours since last servicing x 10	Example: BW 56 = 560 hours since last servicing.
BG ...	Total operating hours x 100	Example: BG 56 = 5,600 total operating hours. This counter cannot be reset.
PR ...	Remaining pellet consumption (in tons) until next cleaning is due	Examples: PR -0.9 = another 0.9 t of pellets can be burnt before the next cleaning becomes due. PR 0.2 = cleaning overdue since 0.2 t.
PW ...	Remaining pellet consumption (in tons) until next servicing is due	Examples: PW -2.9 = another 2.9 t of pellets can be burnt before the next servicing becomes due. PW 0.2 = servicing overdue since 0.2 t.
PG ...	Total pellet consumption in tons	Example: PG 66.5 = 66.5 t of pellets have been burnt in total. Cannot be reset.

wodtke GmbH • Rittweg 55-57 • D-72070 Tübingen-Hirschau
 Tel. +49 (0) 70 71 / 70 03 - 0 • Fax +49 (0) 70 71 / 70 03 - 50
 info@wodtke.com • www.wodtke.com

Please appreciate that we will not be liable for changes following the printing of this documentation or for printing errors.
 Kurzanleitung_S5_Ausgabe_2011_04_07_Englisch